

Samos

SI 0045 – 2200 E1/E2



Samos SI 0150 E1

Description

Busch Samos SI regenerative blowers are designed for either pressure or vacuum. They are available in single and two stage models so they can operate over a wide range of flow and differential pressure.

Low Maintenance and Environmentally Friendly

Samos low maintenance features include: rugged construction, sealed-for-life bearings, a fan cooled motor and a non-contacting impeller. They are oil-free, have a low power consumption, and are quiet due to internal silencers. Samos blowers can be installed in either a vertical or horizontal position.

Regenerative Blowers

Operating Principle

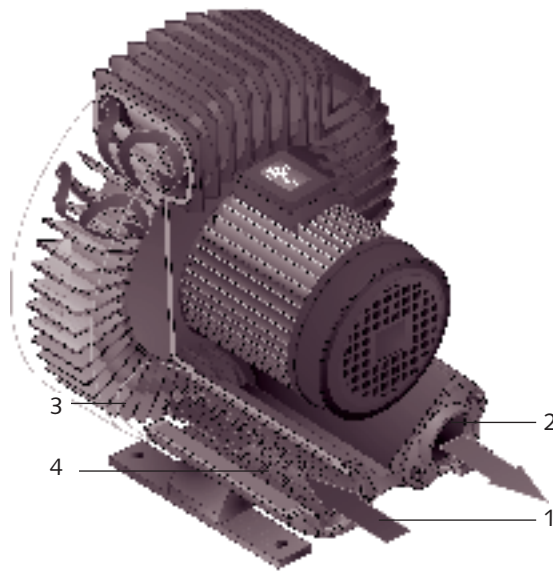

Single-stage version

- 1. Gas Inlet
- 2. Gas outlet
- 3. Impeller
- 4. Silencer

Operating Principle

Gases are drawn in through the blower inlet. As the impeller rotates, it transfers kinetic energy to the gases being pumped. As a result, the gases move forward through a corkscrew shaped path and are compressed, then discharged through the pressure side exhaust silencer. The impeller is mounted directly on the motor shaft.

Applications

- Pneumatic conveying
- Transport and lifting system
- Carton forming and packaging
- Vacuum holddown
- Materials handling
- Soil remediation
- Trim removal
- Wood routers
- Printing industry applications

Dimensions - Samos SI 0045 - 2200 E1 (single stage)

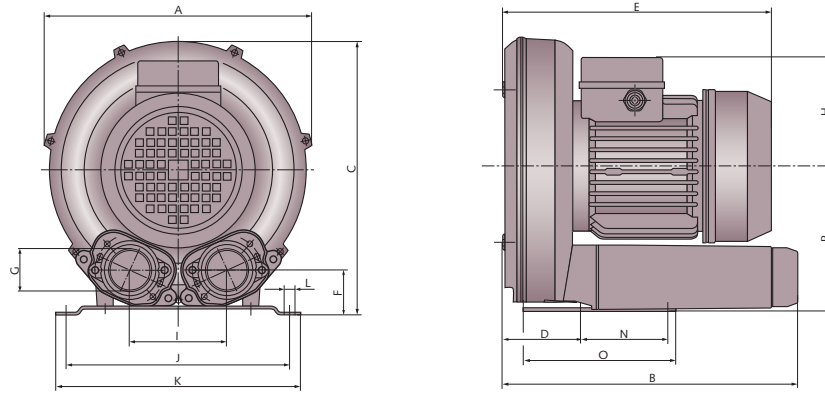

Model	A	B	C	D	E	F	G (BSP)	H	I	J	K	L	N	O	P
SI 0045 E1	7 ¹¹ / ₁₆	7 ⁹ / ₁₆	8 ¹ / ₄	7 ⁷ / ₈	8 ¹ / ₂	1 ³ / ₁₆	1	3 ¹¹ / ₁₆	3 ³ / ₁₆	3 ¹ / ₈	—	3 ³ / ₁₆	1 ¹ / ₈	—	4 ¹ / ₂
SI 0090 E1	9 ⁵ / ₈	10 ¹¹ / ₁₆	9 ⁷ / ₈	2 ⁷ / ₈	9 ¹ / ₈	1 ⁵ / ₈	1 ¹ / ₄	3 ¹⁵ / ₁₆	3 ¹ / ₂	8 ¹ / ₁₆	8 ⁷ / ₈	3 ³ / ₈	3 ³ / ₁₆	5 ¹ / ₂	5 ¹ / ₄
SI 0150 E1	11 ¹⁵ / ₁₆	11 ³ / ₁₆	12 ⁵ / ₈	2 ⁷ / ₈	11 ⁷ / ₈	2 ¹¹ / ₁₆	1 ¹ / ₂	4 ⁹ / ₁₆	4 ⁹ / ₁₆	8 ⁷ / ₈	9 ⁷ / ₈	1 ¹ / ₂	3 ³ / ₄	5 ¹⁵ / ₁₆	6 ⁷ / ₈
SI 0210 E1	13 ³ / ₁₆	11 ⁹ / ₁₆	13 ⁷ / ₁₆	3 ³ / ₈	11 ³ / ₁₆	1 ⁷ / ₈	1 ¹ / ₂	4 ¹¹ / ₁₆	4 ³ / ₄	10 ¹ / ₄	11 ¹ / ₂	9 ⁹ / ₁₆	4 ¹ / ₂	5 ³ / ₄	8 ⁹ / ₁₆
SI 0320 E1	15 ⁹ / ₁₆	12 ⁵ / ₁₆	16 ³ / ₈	4 ³ / ₈	14	2 ¹⁵ / ₁₆	2	4 ³ / ₄	4 ⁵ / ₁₆	11 ⁷ / ₁₆	12 ⁵ / ₈	9 ⁹ / ₁₆	5 ¹ / ₂	9 ¹⁵ / ₁₆	13 ⁵ / ₈
SI 0540 E1	20 ⁷ / ₈	20	23	2	23 ³ / ₄	4 ⁵ / ₁₆	2	7	8 ³ / ₈	15 ⁵ / ₁₆	17 ¹¹ / ₁₆	11 ¹¹ / ₁₆	13 ³ / ₈	15 ³ / ₄	12 ¹ / ₂
SI 1150 E1	22 ⁷ / ₁₆	25 ³ / ₈	24 ⁷ / ₈	1 ¹ / ₈	28 ⁵ / ₁₆	5 ¹ / ₈	4*	8 ⁹ / ₁₆	8 ¹ / ₁₆	18 ⁷ / ₈	21 ¹ / ₁₆	11 ¹¹ / ₁₆	18 ¹ / ₂	20 ¹¹ / ₁₆	13 ⁵ / ₈
SI 1500 E1	22 ⁷ / ₁₆	25 ³ / ₄	24 ¹⁵ / ₁₆	1 ³ / ₈	26	4 ³ / ₄	4*	8 ⁹ / ₁₆	8 ¹ / ₁₆	18 ⁵ / ₁₆	21 ¹ / ₁₆	11 ¹¹ / ₁₆	18 ¹ / ₂	20 ¹¹ / ₁₆	13 ⁵ / ₈
SI 2200 E1	23 ⁵ / ₈	26 ¹ / ₂	24	3 ¹⁵ / ₁₆	26 ¹ / ₂	3 ¹ / ₂	6	8 ⁹ / ₁₆	8 ¹ / ₁₆	17 ³ / ₈	18 ¹ / ₄	1 ¹ / ₂	18 ⁷ / ₈	—	12 ¹ / ₄

*Inlet and outlet is NPT

Dimensions - Samos SI 0500 E1 (single stage)

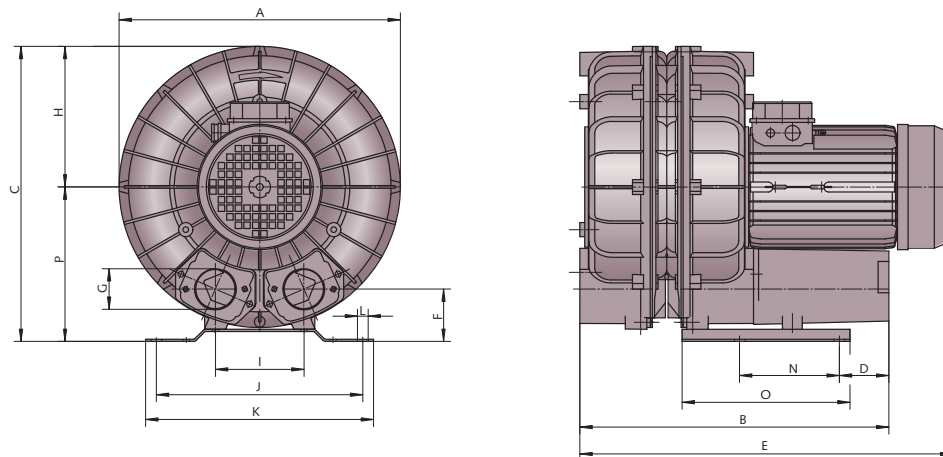

Model	A	B	C	D	E	F	G (BSP)	H	I	J	K	L	N	O	P
SI 0500 E1	15 ⁹ / ₁₆	16 ¹⁵ / ₁₆	16 ³ / ₈	2 ¹ / ₂	20 ³ / ₄	2 ¹⁵ / ₁₆	2	4 ³ / ₄	4 ¹⁵ / ₁₆	11 ⁷ / ₁₆	12 ⁵ / ₈	9 ⁹ / ₁₆	5 ¹ / ₂	9 ⁵ / ₁₆	8 ⁹ / ₁₆

All dimensions in inches unless otherwise noted.

Technical Data - Samos SI 0540 - 2200 E1 (single stage)

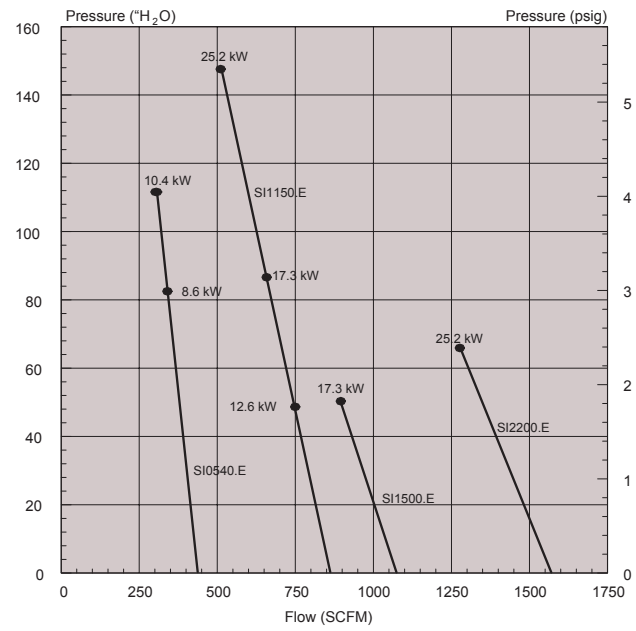
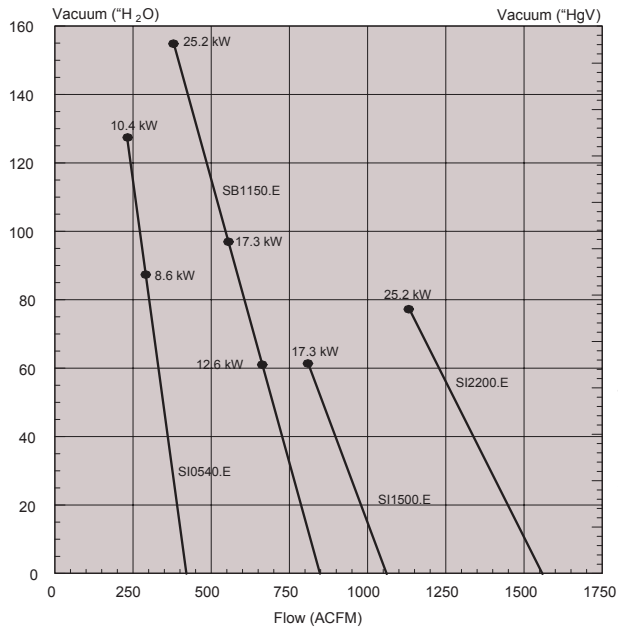

Model	Nominal Pumping Speed ACFM	Max. Vacuum		Max Pressure		Motor (60 Hz)		RPM	Sound** dB (A)	Weight lbs
		"H ₂ O	"Hg	"H ₂ O	psig	kW	Hp			
SI 0540 E1	424	89	6.6	82	3.0	8.6	11.5	3600	80	218
SI 0540 E1	424	126	9.3	115	4.2	10.4	14.0	3600	80	225
SI 1150 E1	848	62	4.6	50	1.8	12.6	16.9	3600	80	295
SI 1150 E1	848	98	7.2	86	3.1	17.3	23.2	3600	80	342
SI 1150 E1	848	156	11.5	148	5.4	25.2	33.8	3600	80	452
SI 1500 E1	1059	62	4.6	50	1.8	17.3	23.2	3600	80	342
SI 2200 E1	1554	78	5.8	66	2.4	25.2	33.8	3600	84	366

** Per DIN EN ISO 2151
Performance data based on ambient conditions of 14.7 PSIA and 70° F, and have a tolerance of +/-10%.



Technical Data - Samos SI 0090 - 0210 E2 (two stage)

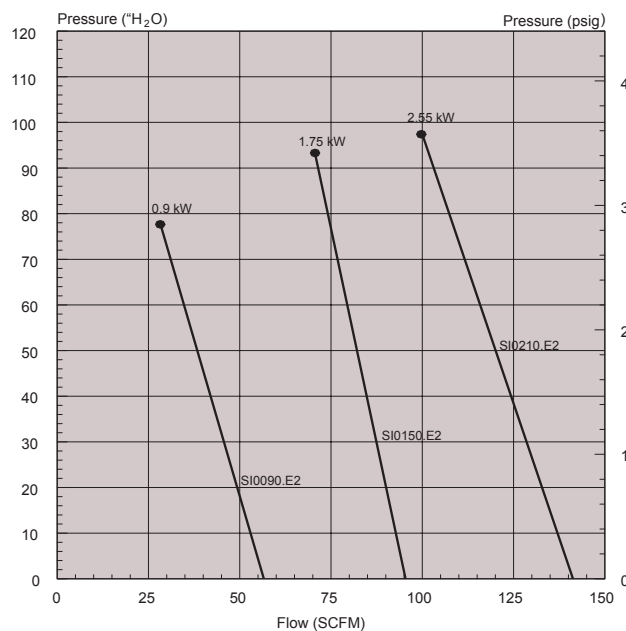
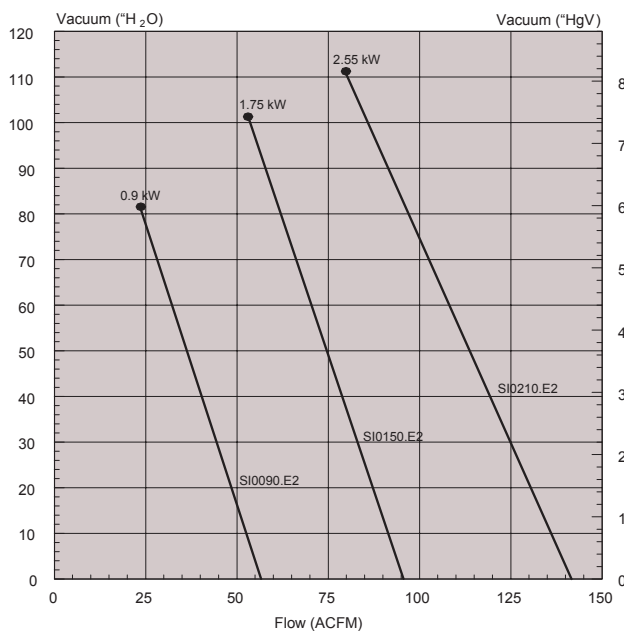

Model	Nominal Pumping Speed ACFM	Max. Vacuum		Max Pressure		Motor (60 Hz)			Sound** dB (A)	Weight lbs
		"H ₂ O	"Hg	"H ₂ O	psig	kW	Hp	RPM		
SI 0090 E2	56	82	6.1	78	2.8	0.9	1.2	3600	68	35
SI 0150 E2	95	102	7.5	94	3.4	1.75	2.3	3600	68	55
SI 0210 E2	141	112	8.3	98	3.6	2.55	3.4	3600	75	68

** Per DIN EN ISO 2151
Performance data based on ambient conditions of 14.7 PSIA and 70° F, and have a tolerance of +/-10%.



Technical Data - Samos SI 0045 - 0500 E1 (single stage)

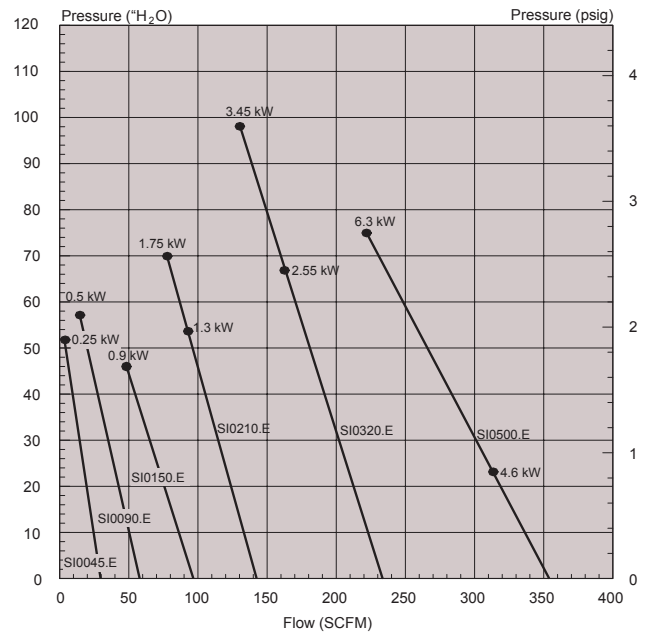
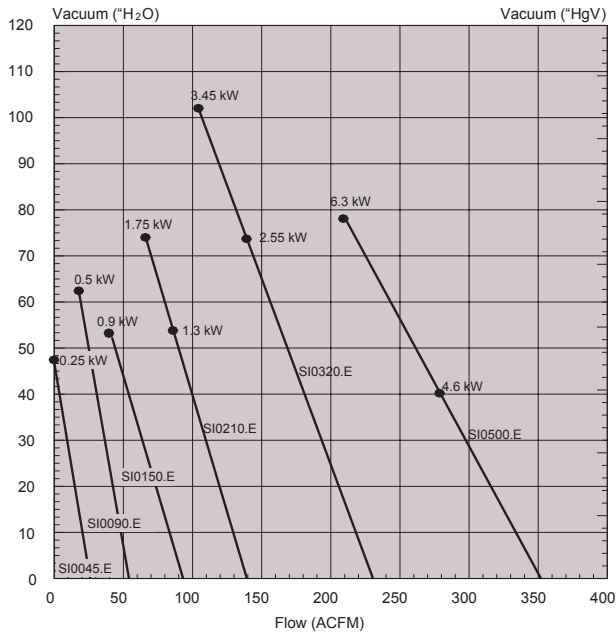

Model	Nominal Pumping Speed ACFM	Max. Vacuum		Max Pressure		Motor (60 Hz)			Sound** dB (A)	Weight lbs
		"H ₂ O	"Hg	"H ₂ O	psig	kW	Hp	RPM		
SI 0045 E1	28	47	3.5	52	1.9	0.25	0.33	3600	60	15
SI 0090 E1	56	62	4.6	58	2.1	0.5	0.67	3600	61	22
SI 0150 E1	95	52	3.8	46	1.7	0.9	1.2	3600	66	40
SI 0210 E1	141	54	4.0	54	2.0	1.3	1.7	3600	71	42
SI 0210 E1	141	74	5.5	70	2.5	1.75	2.3	3600	71	46
SI 0320 E1	232	74	5.5	68	2.5	2.55	3.4	3600	75	66
SI 0320 E1	232	101	7.5	98	3.6	3.45	4.6	3600	75	71
SI 0500 E1 *	353	40	3.0	24	0.9	4.6	6.2	3600	78	123
SI 0500 E1 *	353	78	5.8	74	2.7	6.3	8.4	3600	78	130

*SI0500E1 is dual flow with 2 parallel operating stages

** Per DIN EN ISO 2151

Performance data based on ambient conditions of 14.7 PSIA and 70° F, and have a tolerance of +/-10%.

COMBI SA 450

Technical Data - Samos SI 0320 - 1150 E2 (two stage)

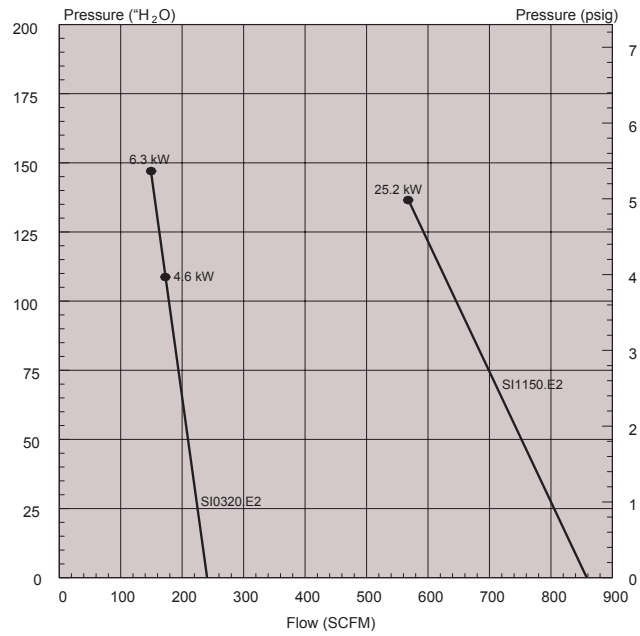
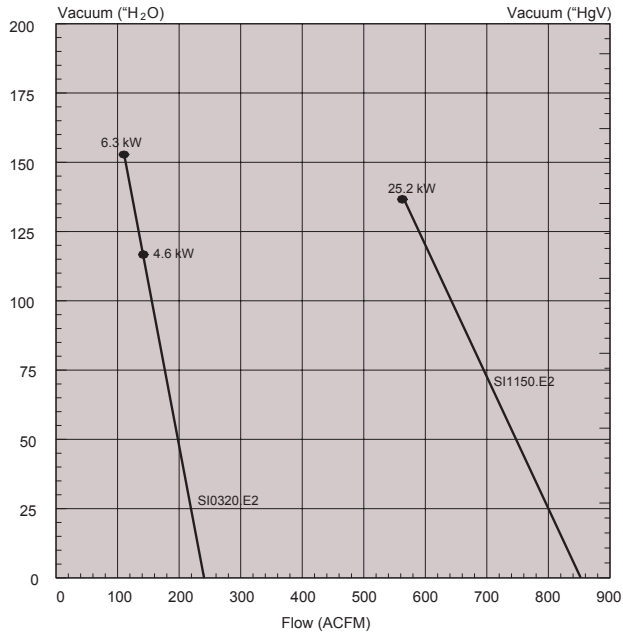

Model	Nominal Pumping Speed ACFM	Max. Vacuum		Max Pressure		Motor (60 Hz)		RPM	Sound** dB (A)	Weight lbs
		"H ₂ O	"Hg	"H ₂ O	psig	kW	Hp			
SI 0320 E2	232	118	8.7	110	4.0	4.6	6.2	3600	78	123
SI 0320 E2	232	152	11.2	149	5.4	6.3	8.4	3600	78	132
SI 1150 E2	848	138	10.2	139	5.0	25.2	33.8	3600	80	529

** Per DIN EN ISO 2151

Performance data based on ambient conditions of 14.7 PSIA and 70° F, and have a tolerance of +/-10%.

Dimensions - Samos SI 0090 - 0320 E2 (two stage)

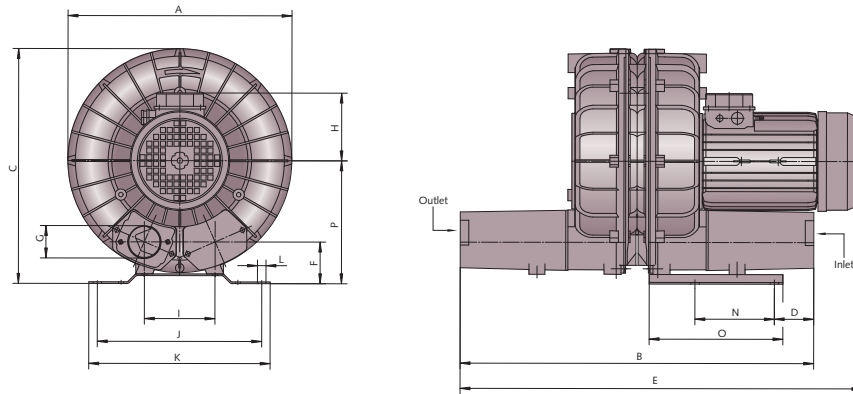

Dimensions - Samos SI 1150 E2 (two stage)

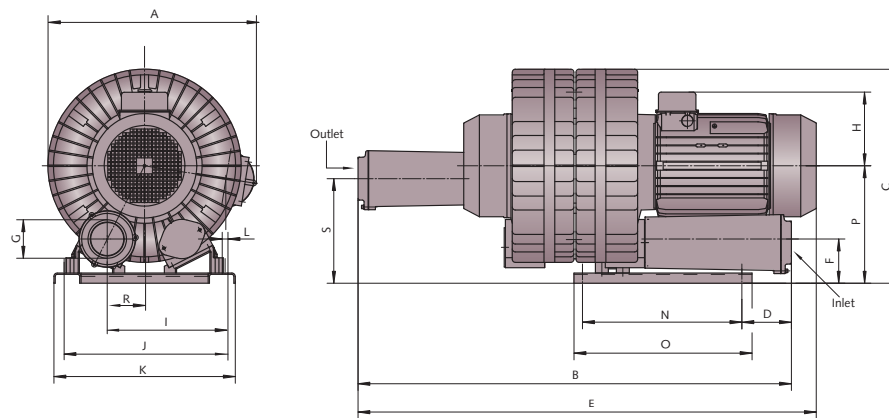

Model	A	B	C	D	E	F	G (BSP)	H	I	J	K	L	N	O	P
SI 0090 E2	9 ¹¹ / ₁₆	21 ¹ / ₁₆	10 ¹¹ / ₁₆	5 ¹⁵ / ₁₆	20 ³ / ₁₆	1 ⁵ / ₈	1 ¹ / ₄	4 ¹ / ₁₆	3 ¹ / ₂	8 ¹ / ₁₆	8 ⁷ / ₈	3 ³ / ₈	3 ³ / ₁₆	5 ¹³ / ₁₆	5 ¹ / ₄
SI 0150 E2	11 ¹⁵ / ₁₆	19 ¹¹ / ₁₆	12 ¹ / ₂	4 ³ / ₄	21 ⁷ / ₁₆	2 ³ / ₈	1 ¹ / ₂	4 ⁹ / ₁₆	4 ¹ / ₈	8 ⁷ / ₈	9 ⁷ / ₈	1 ¹ / ₂	3 ³ / ₄	5 ⁷ / ₈	6 ¹ / ₂
SI 0210 E2	13 ³ / ₁₆	22 ⁷ / ₈	13 ⁷ / ₁₆	8 ¹ / ₈	23 ¹ / ₂	1 ⁷ / ₈	1 ¹ / ₂	4 ³ / ₄	4 ³ / ₄	10 ¹ / ₄	11 ¹ / ₂	9 ⁹ / ₁₆	4 ⁹ / ₁₆	5 ¹³ / ₁₆	6 ⁷ / ₈
SI 0320 E2	15 ⁹ / ₁₆	24 ¹ / ₁₆	16 ³ / ₈	2 ¹ / ₂	27 ¹¹ / ₁₆	2 ¹⁵ / ₁₆	2	4 ³ / ₄	4 ¹⁵ / ₁₆	11 ⁷ / ₁₆	12 ⁵ / ₈	9 ⁹ / ₁₆	5 ¹ / ₂	9 ⁵ / ₁₆	8 ⁹ / ₁₆

Model	A	B	C	D	E	F	G (BSP)	H	I	J	K	L	N	O	P	R	S
SI 1150 E2	24 ¹ / ₄	50 ⁵ / ₁₆	24 ⁷ / ₈	5 ³ / ₄	53 ¹ / ₄	5 ¹ / ₈	4*	8 ⁹ / ₁₆	13 ¹³ / ₁₆	18 ³ / ₄	21 ¹ / ₁₆	11 ¹ / ₁₆	18 ¹ / ₂	20 ¹¹ / ₁₆	13 ⁵ / ₈	4 ³ / ₈	12 ¹ / ₈

*Inlet and outlet is NPT

Busch - all over the world in industry

ISO 9001 Registered Company

Busch LLC 516 Viking Drive Virginia Beach, VA 23452
Phone (757) 463-7800 FAX (757) 463-7407

www.buschusa.com
1-800-USA-PUMP

Amsterdam Barcelona Birmingham Basel Brussels Dublin Göteborg Helsinki Istanbul Copenhagen Kuala Lumpur Milan Maulburg Melbourne Montreal Moscow
 New York New Plymouth Oslo Paris San Jose São Paulo Seoul Singapore Taipei Tokyo Vienna