

## Panda WV 0500-2000



Panda WV 1000

### Description

Panda vacuum boosters are dry-running and used together with backing pumps in all rough and fine vacuum applications where high pumping speeds are required. Panda vacuum boosters work completely contact-free and without seal fluids such as oil or water in the working chamber. Thanks to the large selection of design sizes, the suction capacity and ultimate pressure can be designed optimally in economic terms, and matched exactly to the process conditions.

The high volumetric efficiency is a further factor that increases the economy of operation.

Panda vacuum boosters are safe to operate due to the sturdy, tried and tested design. The integrated bypass valve makes operation possible from atmospheric pressure to ultimate vacuum.

Thanks to variable, horizontal or vertical pumping direction, the Panda is application oriented.

### Features and Options

- Vertical flow
- Horizontal discharge available
- Integral bypass valve
- Sealing rings prevent oil from entering pumping chamber
- Gauge ports for auxiliary instrumentation
- Double shaft seals on drive shaft prevent air leakage
- C flange, direct-drive motor
- Modular design with O-ring seals permits easy service
- Optional temperature switch
- Optional water-cooling of oil sumps
- Oxygen version available
- Food Packaging version available

# Rotary Lobe Vacuum Booster

## Operating Principle

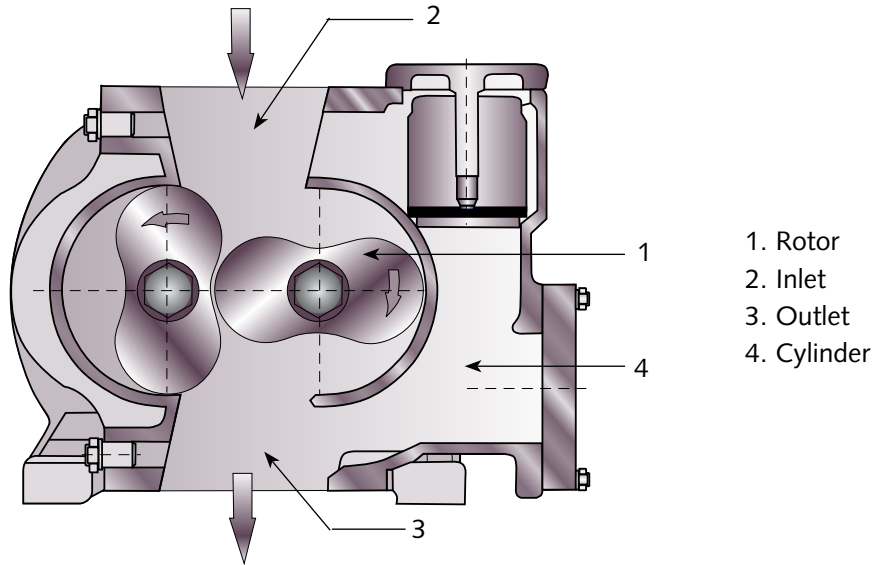

## Operating Principle

Panda vacuum boosters work with two rotary lobes arranged parallel and rotating in opposite directions of rotation.

During the contact free rolling process, the conveyed volume is separated off on the inlet side between lobe and housing and then pumped to the pressure side. No lubricants or sealants are required in the pumping chamber for the contact free operation. Panda vacuum boosters have a bypass valve fitted as a standard feature which limits the differential pressure between the inlet and the outlet.

## Function of the bypass valve

The bypass valve consists of a connection between inlet and pressure sides of the Panda, which is located outside of the conveying chamber. A mechanical valve is built into this connection and opens when the pressure difference is exceeding the determined maximum value. This allows that part of the pump gas to be returned to the inlet. This bypass valve allows the operation of the vacuum booster together with the backing pump at atmospheric pressure, avoiding any overload of the pump or the motor. The main advantage is to allow the booster to cycle frequently between higher and lower inlet pressures without turning the motor off.

## Applications

Panda vacuum boosters are used together with other vacuum pumps (backing pumps) in vacuum systems or vacuum pump groups.

Oil-lubricated rotary vane vacuum pumps of the R 5 series or COBRA dry screw vacuum pumps are suitable as backing pumps. Ideal applications include those where high speed evacuations to low ultimate pressures are required in a frequent cycle.



## Technical Data

Booster/Pump Characteristic Curve

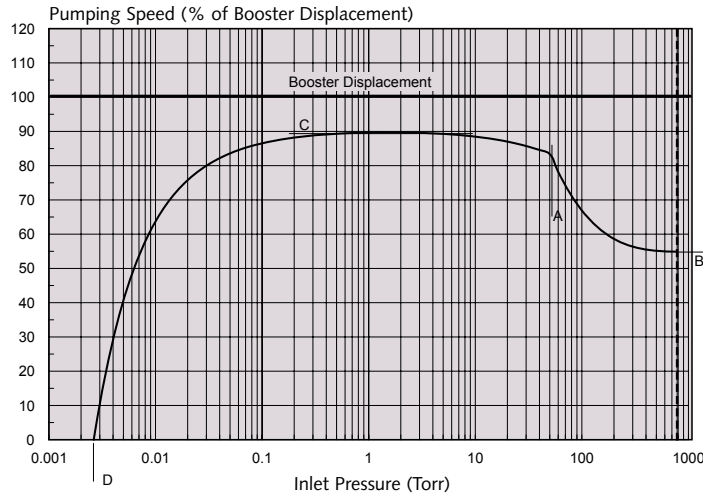

Actual performance curve will depend on the booster model, the backing pump performance curve and additional factors.

- A = Bypass valve cracking point - Dependant on differential pressure of valve and the volumetric ratio ( $V1/V2$ ) (booster/pump).
- B = Flow @ atmospheric pressure - Dependant primarily on backing pump capacity.
- C = Nominal flow of booster - Dependant primarily on the displacement of the booster and the capacity of the backing pump selected.
- D = Ultimate pressure - Dependant primarily on the ultimate pressure of the vacuum pump selected and the volumetric ratio.

Consult the factory for actual curve and application of vacuum boosters.

Technical Data		WV 0500	WV 1000	WV 1500	WV 2000
<b>Panda Model</b>					
Nominal displacement	CFM	353	765	1060	1530
Maximum leak rate	Torr-CFM	$2.8 \times 10^{-2}$	$2.8 \times 10^{-2}$	$2.8 \times 10^{-2}$	$2.8 \times 10^{-2}$
Maximum differential Pressure	Torr	40	32	32	32
Motor Size	HP/Kw	3/2.2	5/4	7.5/5.5	10/7.5
Rotational Speed	RPM	3600	3600	3600	3600
Approximate module weight	Lbs	315	520	634	1200
Oil Capacity	Qt	1.25	3.2	3.2	5

Performance data based on ambient conditions of 14.7 PSIA and 70° F, and have a tolerance of +/-10%.

# Rotary Lobe Vacuum Booster



## Dimensions

WV 0500

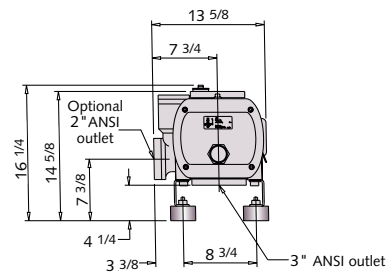
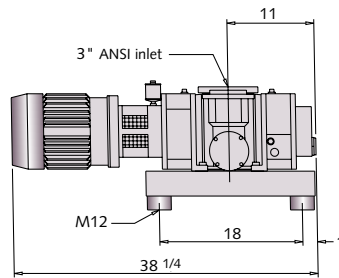

WV 1000

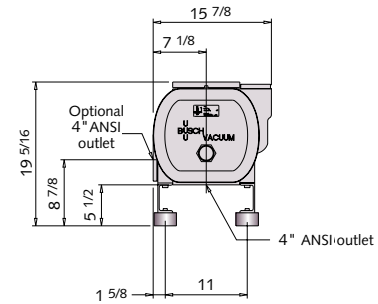
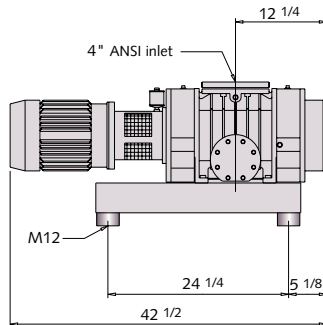

WV 1500

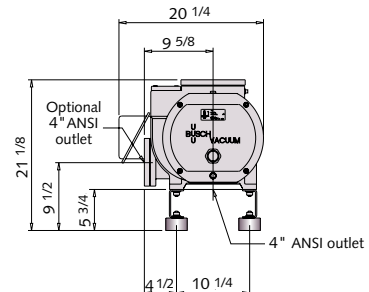
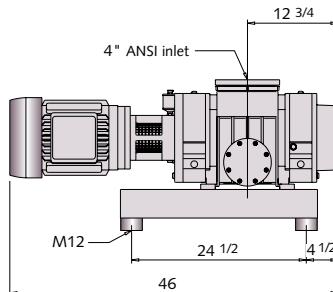

WV 2000

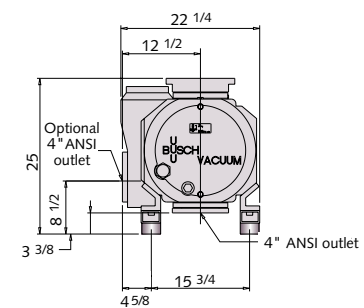
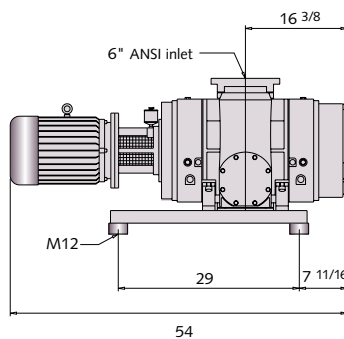

\*All dimensions in inches unless otherwise noted.

**Busch - all over the world in industry**

**ISO 9001 Registered Company**

**Busch LLC 516 Viking Drive Virginia Beach, VA 23452  
Phone (757) 463-7800 FAX (757) 463-7407**

**www.buschusa.com  
1-800-USA-PUMP**

Amsterdam Barcelona Birmingham Basel Brussels Dublin Göteborg Helsinki Istanbul Copenhagen Kuala Lumpur Milan Maulburg Melbourne Montreal Moscow  
New York New Plymouth Oslo Paris San Jose São Paulo Seoul Singapore Taipei Tokyo Vienna

Models and specifications are subject to change without notice

Panda-02-04/09